

DRAWING REVISIONS

LTR	BY	DATE	ECO #	DESCRIPTION
A	CNS	12/17/12		RELEASE
B	JDC	01/15/15		REM. WEB ACCESS NOTE
C	JHR	8/26/15		UPDATE LABEL REV. C
D	JHR	4/25/17		ADD AUXILIARY OUTPUT NOTE
E	GMP	09/28/17		UPDATE ZOELLER LOGO & BORDER
F	GMP	02/27/20		SHOW VERTICAL REED SWITCH

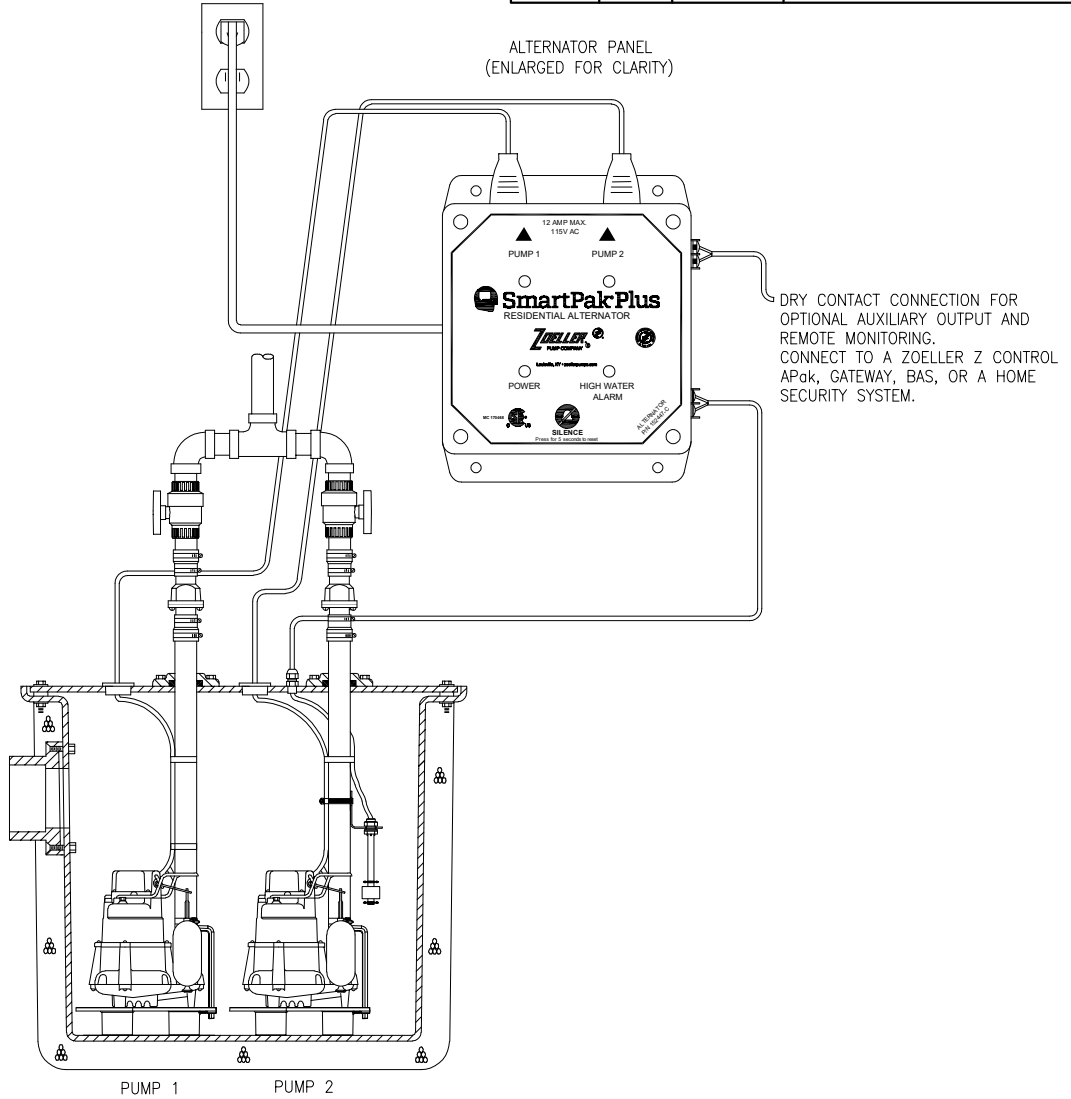

PUMP 1 PUMP 2

DRAWING DESCRIPTION:
INST. INSTR.
RESIDENTIAL ALTERNATOR
CONTROL PANEL

NUMBERS ENCLOSED IN A CIRCLE; ①, ARE CRITICAL TO QUALITY (CTQ) ITEMS. THIS INDICATES A CRUCIAL SPECIFICATION THAT MUST BE ROUTINELY VERIFIED.

ITEMS MARKED (CTQ) ARE CONTROLLED BY A SEPARATE DIVISION'S QUALITY SYSTEM.

TOLERANCES:

.X ±~ .XXXX±~
.XX ±~ ANGLES ±~
.XXX ±~ FRACTIONS ±~

CHECKED:
APPROVED:

DRAFTER:
C. SCANLON

DATE:
12/17/12



ELECTRONIC SCALE: NONE
DO NOT SCALE PRINT

PART NUMBER: PART REVISION:

~ ~

EXCEPT AS NOTED
DIMENSIONS ARE IN INCHES.

DRAWING NUMBER:

SHEET: 1 OF 1

SK2954